



# ***ASTRALS Platform Description***

***Charline Guguen, Karsten Grüneberg***  
***Thomson, HHI***

**December 14<sup>th</sup>, 2007**

# ***ASTRALS Platform Description***



- **Overall Platform Description**
  - One Residential Gateway
  - Several Audio / Video subsystem boxes
  - One wireless system extension
- **Highlight on one SVC usage over the wireless network**

# Overall Platform Description



- **ASTRALS platform is composed of**
  - One Residential Gateway
    - *The Home Network manager and supervisor*
  - Several Audio / Video subsystem boxes
    - *The encoding and streaming platform*
  - One wireless system extension
    - *Based on the 802.16 standard*

# ***The Residential Gateway***



- **HW implementation**
  - It has been integrated in the same HW platform has the A/V sub-system
  - One of the A/V sub-system is the master with RG embedded functionalities
- **Functionalities**
  - Home gateway to access network
  - Supervisor for home network management and services

# Overall Platform Description



- **ASTRALS platform is composed of**
  - One Residential Gateway
    - *The Home Network manager and supervisor*
  - Several Audio / Video subsystem boxes
    - *The encoding and streaming platform*
  - One wireless system extension
    - *Based on the 802.16 standard*



# The Audio/Video Subsystem (1)

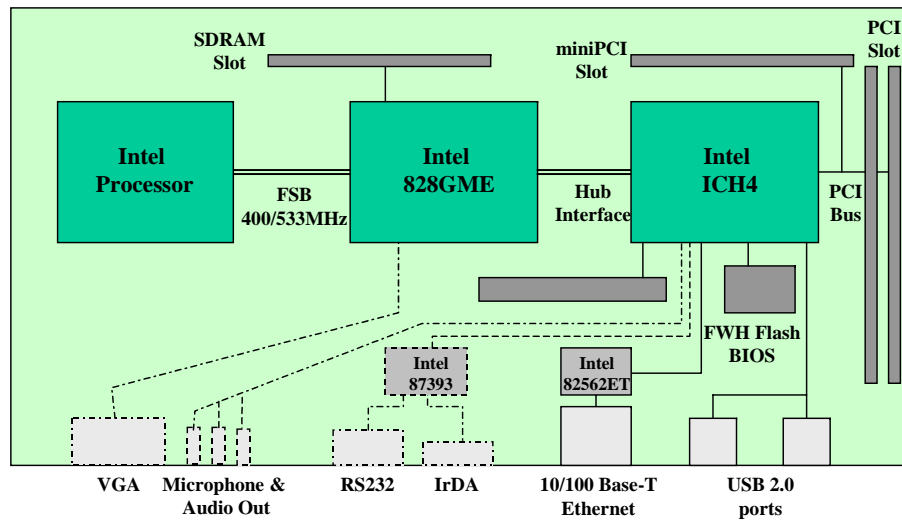

# The Audio/Video Subsystem (2)



<b>Hardware implementation features:</b>	
<b>CPU</b>	<i>Intel Pentium-M (up to 2.2GHz), FSB: 400/533MHz, L2 Cache: up to 2MB</i>
<b>Supporting Chipset</b>	<i>Intel 828GME and ICH4</i>
<b>Memory</b>	<i>DDR 266/333 SDRAM up to 1GB</i>
<b>Flash</b>	<i>8Mbits</i>
<b>PCI Enhanced IDE</b>	<i>UltraATA/100 IDE</i>
<b>PCI Interface, MiniPCI</b>	<i>Up to 2 PCI slots, up to 2 miniPCI slots</i>
<b>Network Interface</b>	<i>10/100 Base-T</i>
<b>USB</b>	<i>Up to 6 USB 2.0</i>
<b>DiskOnModule, VGA, IrDA, RS-232, Compact Flash (Type II)</b>	<i>Optional</i>
<b>IEEE 802.11 b/g, IEEE 1394, BNC</b>	<i>Optional (via PCI or miniPCI card)</i>

# The Audio/Video Subsystem (2)

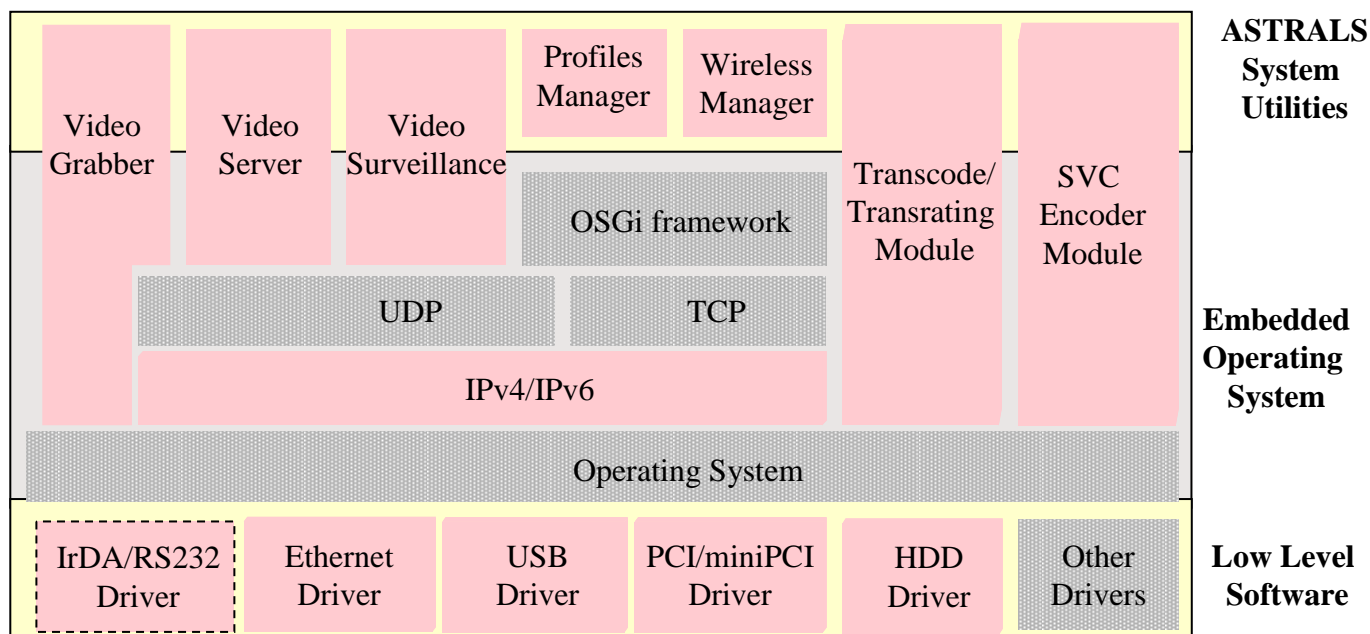

# The Audio/Video subsystem (3)



- Functionalities:
  - SVC coding and delivery (streaming)
  - SVC storage featuring Storage Erosion
  - SVC payload format and signalling
  - Transcoding functionalities
    - For non SVC supporting devices
    - MPEG2 to MPEG4
  - Transrating functionalities
    - To adapt video streaming bit rate to the available data rate of the medium used for the transmission (cable, wireless, power line, ...)



# The Audio/Video Subsystem (4)

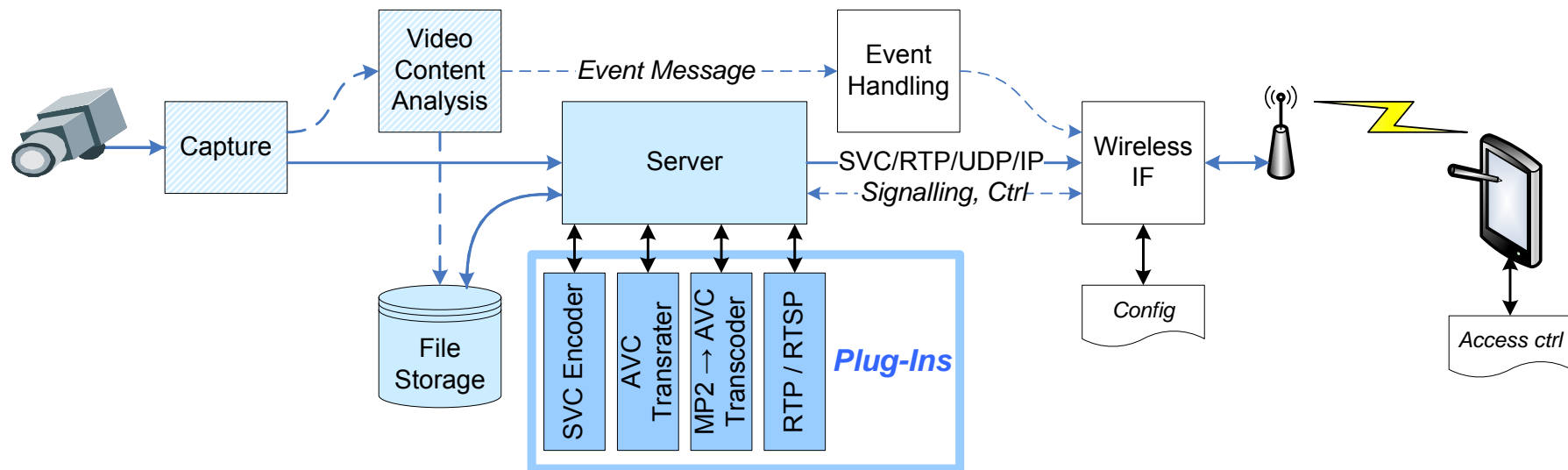

## Operation modes:

- Capture, analyze and store
- SVC encoding
- AVC Transrating
- Transcoding (MPEG2 → AVC)
- Streaming from file

## Applications:

- Home Surveillance
- Health care application
- Surveillance of elderly people, baby-sitting
- Multimedia services
- Home automation and monitoring

# Overall Platform Description



- **ASTRALS platform is composed of**
  - One Residential Gateway
    - *The Home Network manager and supervisor*
  - Several Audio / Video subsystem boxes
    - *The encoding and streaming platform*
  - One wireless system extension
    - *Based on the 802.16 standard*



# The wireless sub-system (1)

- Protocol stack and hardware implementation

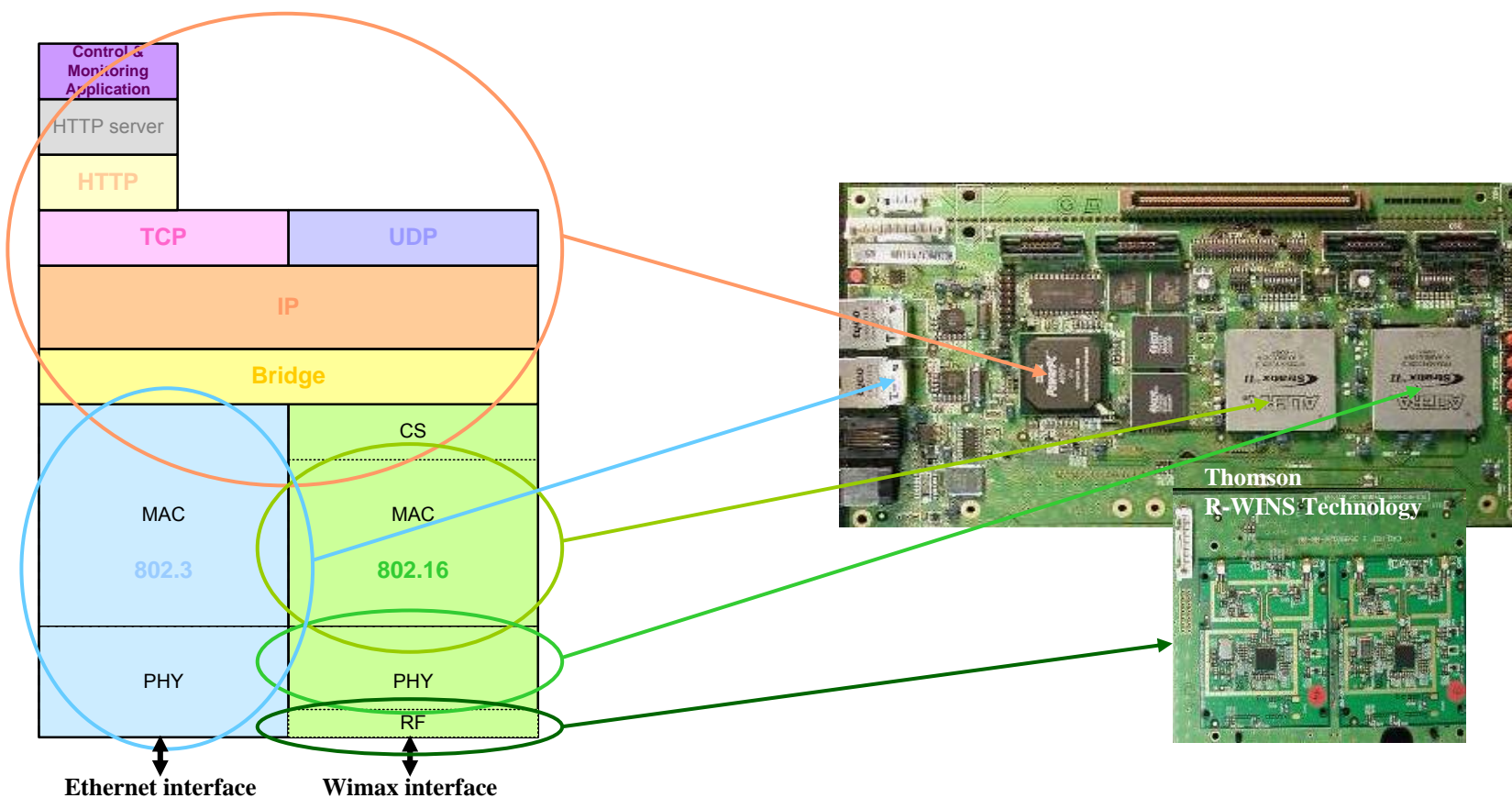

# The wireless sub-system (2)



- **Functionalities**
  - Based on the 802.16d standard + proprietary add-ons
  
  - Offer a robust wireless link between home network devices
    - Improved Physical layer in 5GHz band
    - Enhanced home coverage for both LOS and NLOS environments ...
      - *MRC (Maximum Ratio Combining) technique*
  
  - Be able to deliver real-time video streaming with a true Quality-of-Service
    - High efficient MAC (90%)
      - *Fast ARQ (Automatic Repeat reQuest) dedicated to video applications*
    - Dedicated optimized scheduler and classifier



## The wireless sub-system (3)

- Easy configurable thanks to Control & Monitoring application (html/http)

**THOMSON**  
images & beyond

**THOMSON Multimedia Wireless kit Control front panel**

**BS Configuration - wireless parameters**

Local Mac Address: 00.00.00.00.00.00

Initial Tx Power (dB): 14

Broadcast modulation: QPSK 1/2

Frame period: 2,5

Time guard (Tg): 1/8

Initial ranging duration: 1

Initial ranging periodicity: 13

Midamble repetition interval: 8

Downlink preamble present: yes

Downlink midamble interval: no

Nb of frequencies: 2

Frequency #1 (kHz): 5500000

Frequency #2 (kHz): 5520000

Frequency #3 (kHz): 0

**THOMSON**  
images & beyond

**THOMSON Multimedia Wireless kit Control front panel**

**SS Connections characteristics**

CID	Direction	ARQ	Maximum traffic rate (kbps)	Scheduling type	To be saved
35	Uplink	Disabled	250	rtPS	<input type="checkbox"/>
32	Uplink	Disabled	64512	urtPS	<input type="checkbox"/>
36	Downlink	Disabled	250	rtPS	<input type="checkbox"/>
34	Downlink	Disabled	17000	rtPS	<input type="checkbox"/>
33	Downlink	Disabled	64512	urtPS	<input type="checkbox"/>

Save-connections

Create-connection

Delete-connection

View-detailed-connection

# The wireless sub-system (4)



- **Astrals environment**

- Connection / Interaction with the Residential Gateway (RG) and several home networking equipments



- **Astrals wireless infrastructure**

- 1 Access Point
- 2 Remote Stations

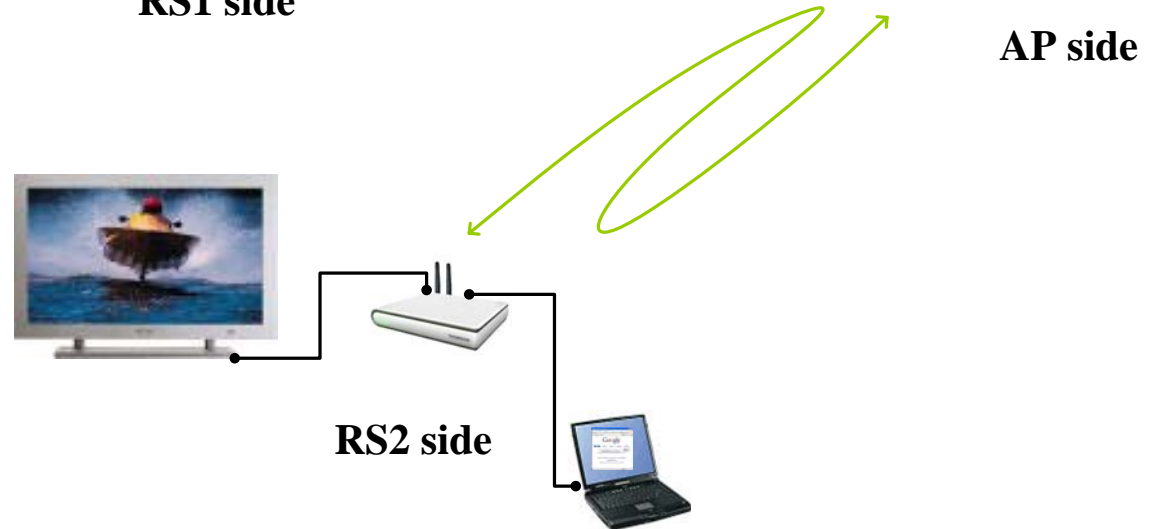

# ***ASTRALS Platform Description***



- Home Network context & ASTRALS infrastructure ?
- Overall Platform Description
- **Highlight on one SVC usage over the wireless network**

# ***Using SVC over wireless network***



- **One of the ASTRALS aims is**
  - ⇒ **to get the most advantage from SVC capabilities on one hand and of wireless capabilities on the other hand.**
- **SVC, layered video coding capabilities (quality, resolution, frame rate)**
- **802.16 wireless system, a robust true QoS optimized wireless network**



# Layered Multicast based on SVC

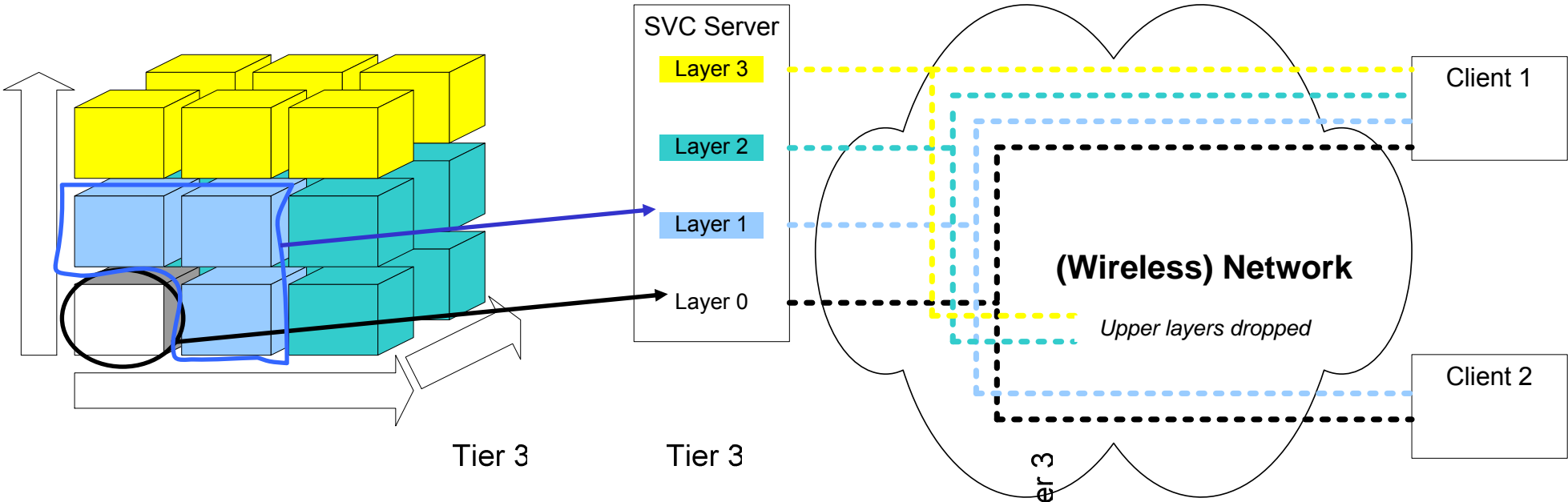

- **SVC allows to define several "Operation Points" in three dimensions of scalability**

→ different quality level layers mapped on different multicast streams

- **Desired Network behaviour:**

- Efficient use of link capacity
- Convey as much data rate as possible to each client
- Avoid redundancy (compared to multiple unicast transmissions)
- Data rate adaptation by just subscribing to a subset of the multicast streams

Base Tier (0)

Tier 1

Tier 2

ASTRALS Consortium Proprietary



# SVC Transmission Over Wireless Links

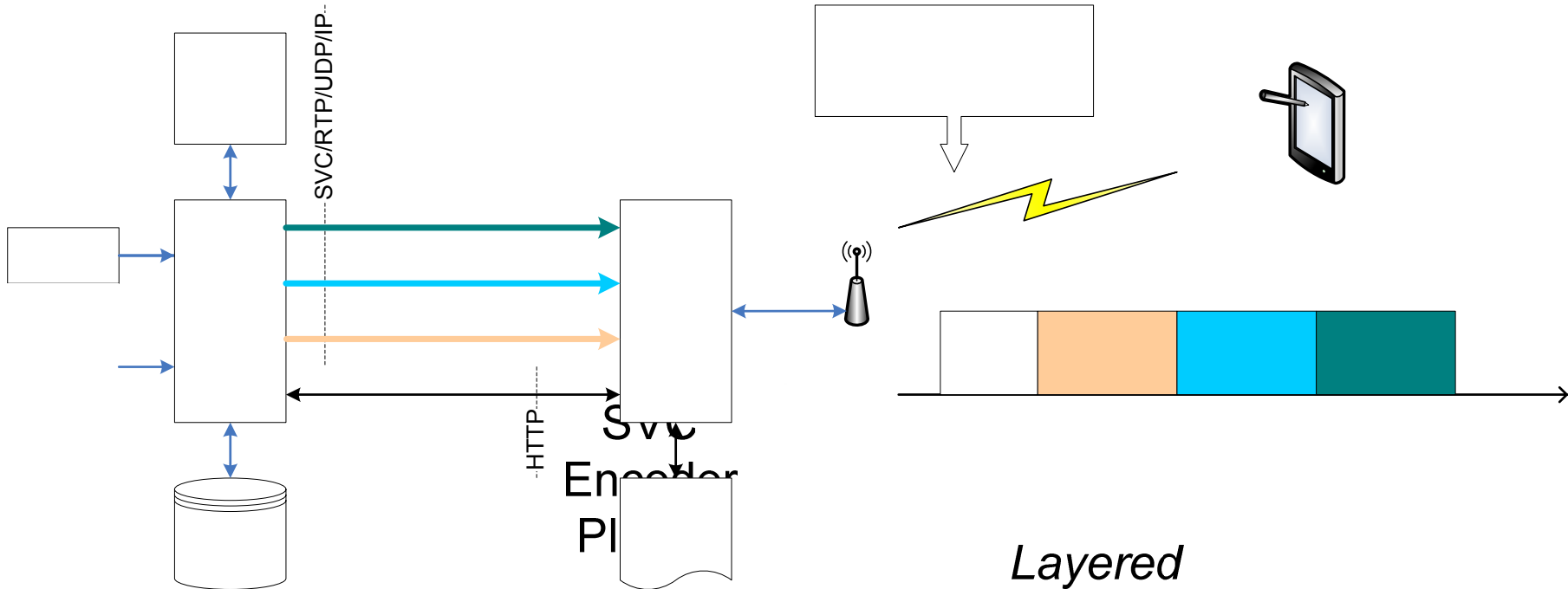

- Layered multicast to different streams (RTP, ...), on different multicast ARQ connections on the wireless link
- Differentiate robustness for each layer by distinct PHY parameters for each multicast streams

*Layered Multicast*

RTP3 (Enh. Layer2)

RTP2 (Enh. Layer1)

RTP1 (Base Layer)

Configuration / Info

Capture

or

RTP

VLC Server

ASTRAL Consortium Proprietary

Wireless IF 19